

6TH BIENNALE SVIZZERA DEL TERRITORIO

**HANDLE
WITH CARE**



**OCTOBER 1ST – NOVEMBER 28TH
OPENING OCTOBER 1ST – 3RD**

CALL FOR ACTION SELECTION

Total proposals: 246

Selected proposals (10):

**1_aesthetics of care: borrowed
sceneries**

2_ CAR^CAR space

3_Edible Curtains

4_Handles with Care

5_(IN)VISIBLE GESTURES

6_MANU TENERE

7_May the earth be light upon you

8_Sit For A While

9_Surface de réparation

10_Under the canopy

In alphabetical order

1 aesthetics of care: borrowed sceneries

strata collective
(Maja Liro & Zofia Krupa)

Based in Zurich (Switzerland)



Left to right: Maja Liro & Zofia Krupa
©strata collective

1 aesthetics of care: borrowed sceneries

aesthetics of care: borrowed sceneries challenges the aesthetics of a strictly maintained garden, transforming the basin designed by Willi Neukom into a scenography where care becomes visible through the use of water, stone and planting.

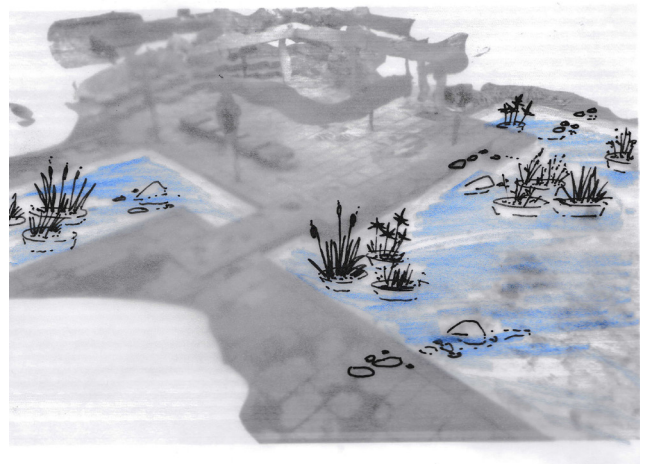

- ▲ Drawings of the authors
- ◀ Rendering of the authors

2 CAR^CAR space

Giona Bierens de Haan

Based in Genève (Switzerland)



◀ Portrait © Giona Bierens de Haan

▼ Axonometry © Giona Bierens de Haan

2 CAR^CAR space

Each year, 200,000 cars are taken out of circulation. Two-thirds of them are sent to neighboring countries where more flexible regulations are in force. What if we instead undertook the exercise of revalorizing our resources rather than sending them elsewhere? a lightweight textile roof. The two metal structures supporting the fabric are attached to the car bodies using suction cups. At night, the car radios switch on, the headlights illuminate the dance floor, and the space transforms into a place of celebration.

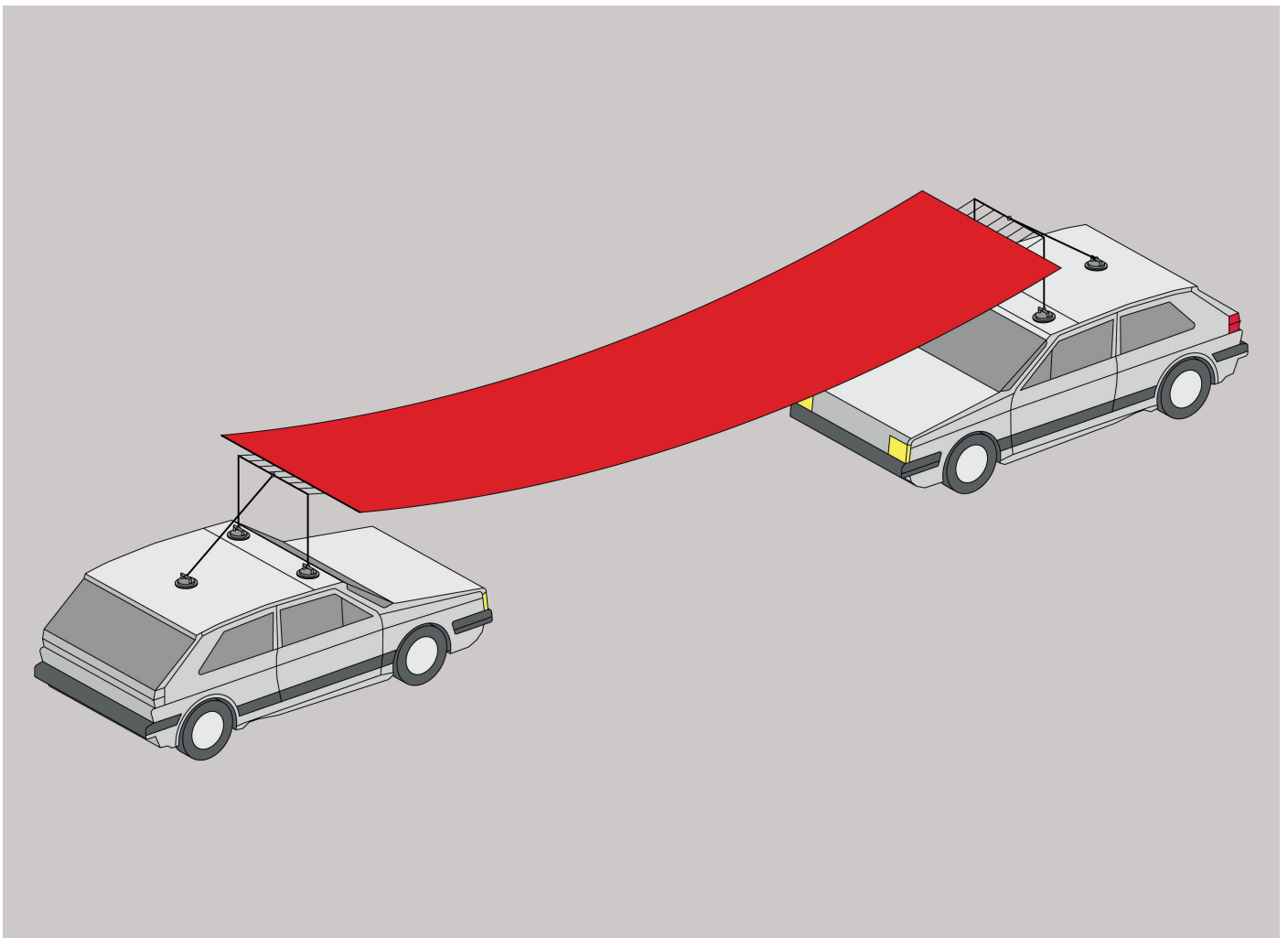

3 Edible Curtains

**Johanna Roth, Alanis Diem,
Anne-Sophie Bruderer**

Based in Zurich (Switzerland)



▲ Territory Stone Quarry Barlöcher, Johanna Roth
▶ Ph Pierre Marmy

3 Edible Curtains

Edible Curtains is a project of care towards territory, attending to what is seasonal, material, and alive. It roots itself in wine production, transforms it, and offers it back as something spatial to be touched, shared, and performed.

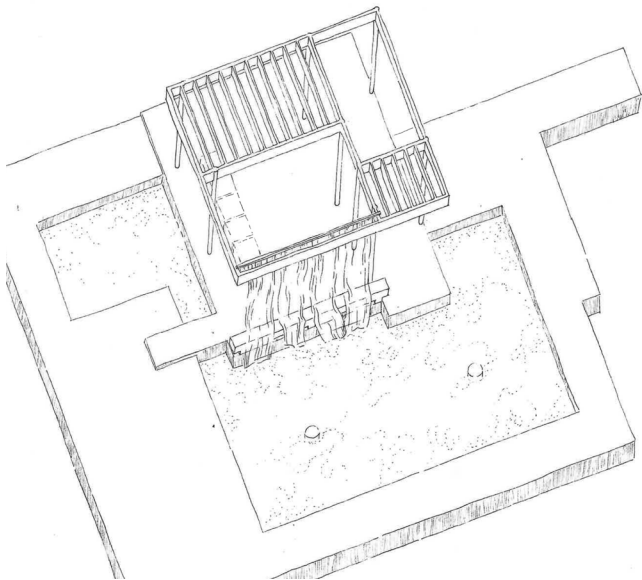

▲ Drawing of Johanna Roth and Anne-Sophie Bruderer

► Rendering of Johanna Roth

4 Handles with Care

**Marta Wiśniewska +
Filip Pawłowski**

Based in Warsaw (Poland)



Left to right: Filip Pawłowski and Marta Wiśniewska

4 Handles with Care

Handles with Care reflects on care as a bodily practice of use and responsibility. Through touch, two handles enact care in two ways: soft / comforting, sterile / protective, negotiating between comfort and control.

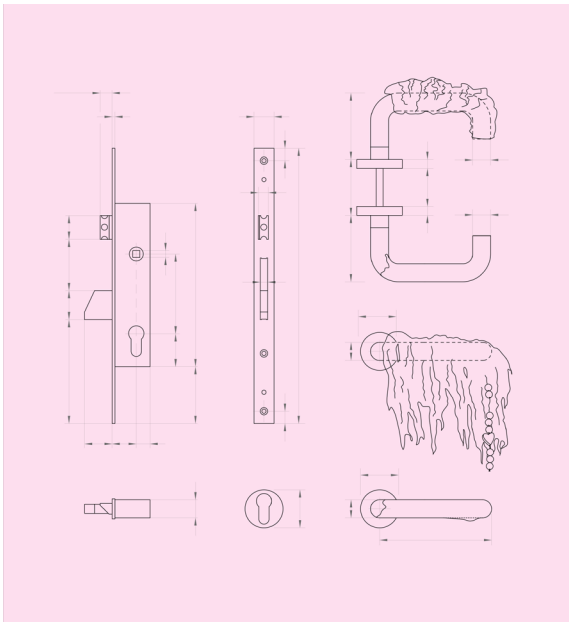

▲ Drawing of the authors

► Ph Marta Wiśniewska + Filip Pawłowski

5 (IN)VISIBLE GESTURES

how:about (Ludovica Brizio, Marta Cas-sany, Arianna Frascoli, Marta Locarno, Isolde Michelazzi, Maria Minić, Maša Mori, Beatrice Pedrotti, Elisa Sassi) x **fuoriluga**

Based in Zurich / Lugano
(Switzerland)



© Valentine-Blaimont



Movie projection in the garden of Fuoriluga (in collaboration with the Festival dei Diritti Umani di Lugano), Porza 2025 ©Fuoriluga

5 INVISIBLE GESTURES

How about collective actions and everyday gestures of care as essential urban practice?

Through collective acts, care becomes a tool: an ongoing gesture, a support to inhabit and reimagine the city.



HANDLE W/ CARE

- ▲ Drawing of how:about
 - Redevelopment of an outdoor garden making it usable again for cultural activities and events through deforestation, cleaning, safety measures, and the construction of temporary structures
- ©Fuoriluga



6 MANU TENERE

ALARMA*

*Berta · Bosshard · Chan · Dussau-
It-Cloutier · Epprecht · Henz · Hutma-
cher · Karlovic · Maeder · Mijnsen ·
Nikolic · Staubli · Umar · Zeller

Based in Zurich (Switzerland)



ALARMA*

6 MANU TENERE

Care and maintenance are not opposites, but different intensities of labour in the landscape. Alarma* is interested in the line where they touch: what it holds, what appears. We begin with borderstones, and renegotiate how the land they enclose is worked. Come touch the grass in between.

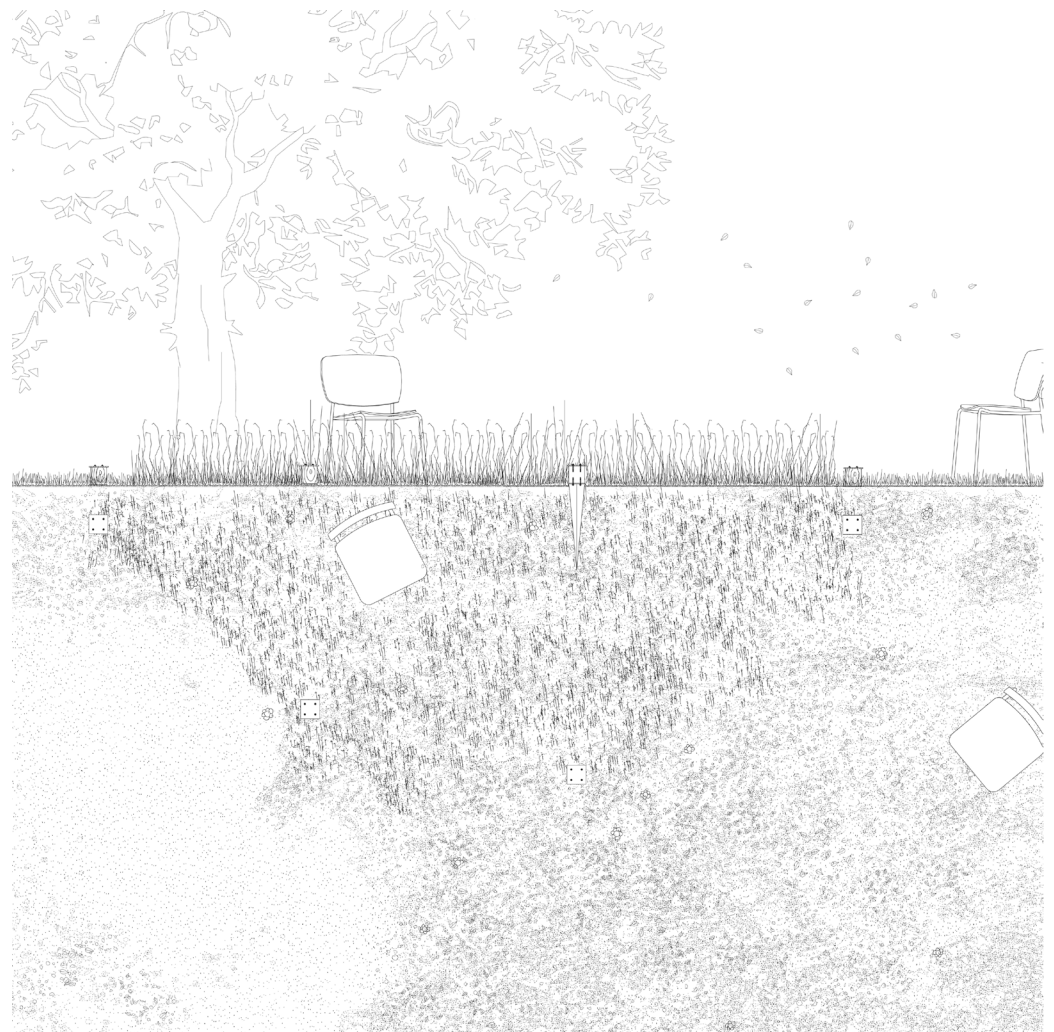

Drawing of the authors

7

May the earth be light upon you

zattere

Based between Milan, London, Buenos Aires, Zurich and Berlin



zattere

8 Sit For A While

SKNYPL
an architectural office running by
Azamat Nyrov and Aleksandr Plotkin

Based in London / Paris
(UK / France)



Left to right: Azamat Nyrov and Aleksandr Plotkin
Ph Giacomo Bianchi

8 Sit For A While

Sit For A While is a mobile observation room that stops beside buildings at risk, asking why they receive attention only at the edge of demolition, whether they were cared for enough, and whether care can truly protect them from destruction.

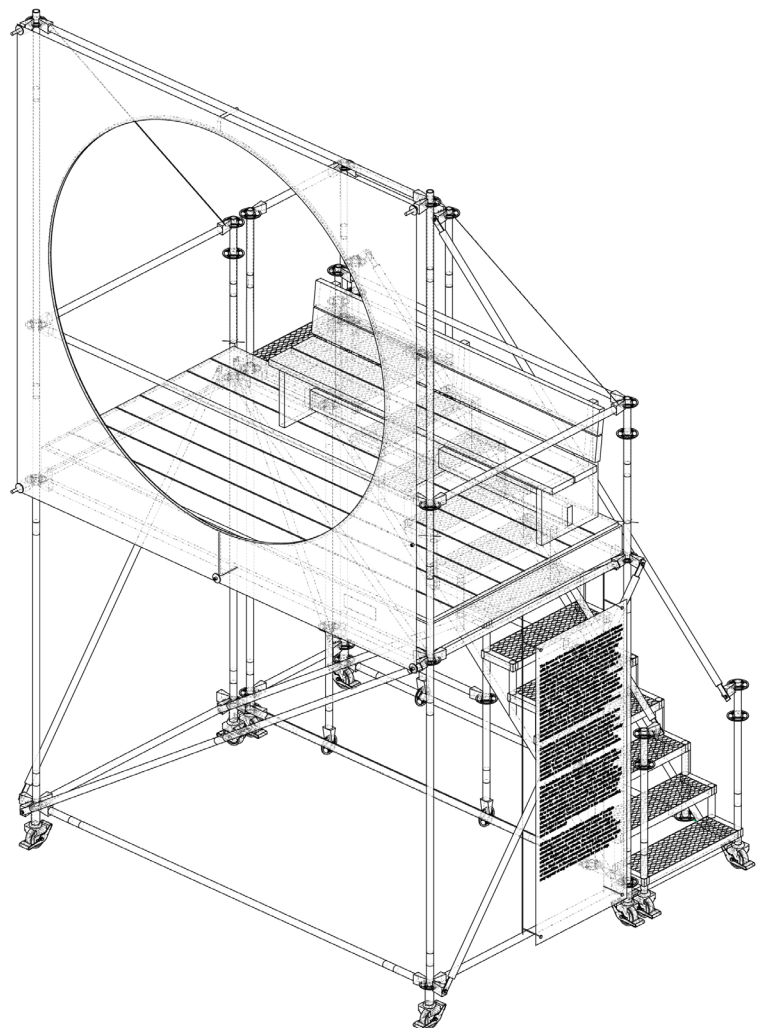
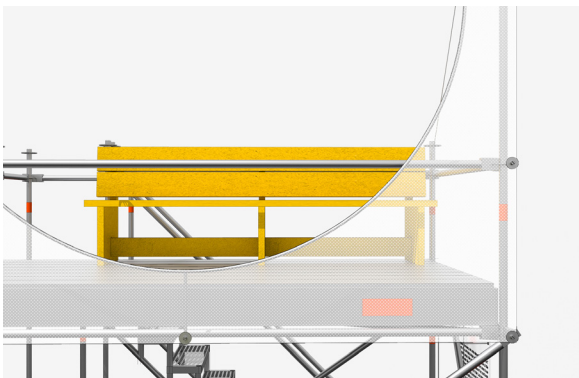

- ▲ Rendering of the authors
- Axonometry of the authors

9 Surface de réparation

**Enea Colombo, Hervé Laurendeau,
Ghita Ouassini, part of Alliage collective**

Based in Milan (Italy), Lausanne and Geneva (Switzerland)



Left to right: Hervé Laurendeau,
Ghita Ouassini, Enea Colombo.

9 Surface de réparation

A soon-to-be displaced football pitch seeks refuge within the historical center: care here is not only maintenance but reclamation, unfolding through acts of play and repair that ensure the surface's rightful occupation.

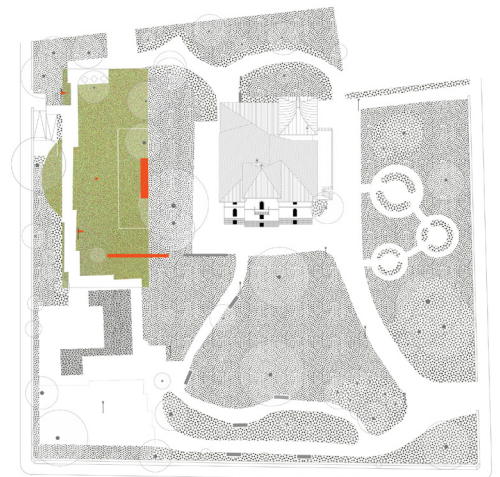

Drawings of the authors

10 UNDER THE CANOPY

Iván Jiménez, Marco Castillo, Daniela Pitizaca, César Pesantez, Yessenia Aguilera, Cristina Cañar

Based in Loja (Ecuador)



Left to right: Yessenia Aguilera, Cristina Cañar, Daniela Pitizaca, Marco Castillo, César Pesantez, Iván Jiménez

10 UNDER THE CANOPY

The tree as a social infrastructure: carefully observing what already exists in order to recognize and make its presence visible, and through a minimal gesture activating a new vitality.

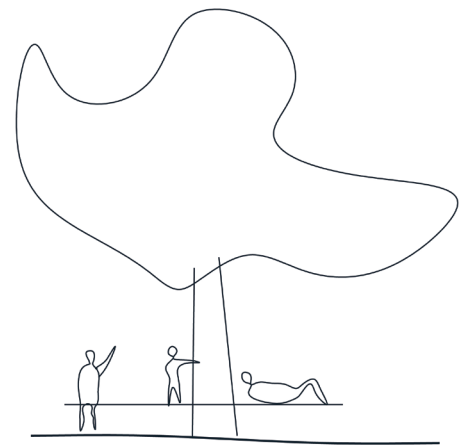

- ▲ Sketch of the authors
- ◀ Rendering of the authors

 Istituto Internazionale
di Architettura

Villa Saroli
Viale S. Franscini 9
6900 Lugano
Switzerland

+41 91 996 13 87
info@i2a.ch
www.i2a.ch